

Sunbeam

Slow Cooker

Instruction/Recipe Booklet

This book covers the use and care of the following Sunbeam slow cookers:

HP5520 Slow Cooker - 5.5 litre slow cooker with crock insert

HP4520 Slow Cooker - 4.5 litre slow cooker with crock insert

Please read these instructions carefully
and retain for future reference.



Contents

Sunbeam's Safety Precautions	1
Features of your Slow Cooker 5.5L - HP5520	2
Features of your Slow Cooker 4.5L - HP4520	4
An introduction to Slow Cooking	6
Using your Slow Cooker	6
Tips for Slow Cooking	7
Care and Cleaning	8
Recipes	9

Important instructions – retain for future use.

تأكد من تفهم احتياطات السلامة المذكورة اعلاه

請務必理解上述的安全預防措施。

Assurez-vous que les précautions ci-dessus relatives à la sécurité sont bien comprises

Versichern Sie sich, dass die obenstehenden Sicherheitsmaßnahmen verstanden werden

Βεβαιώνετε πως οι παραπάνω προφυλάξεις ασφαλείας γίνονται κατανοητές

Pastikan bahwa tindakan-tindakan keselamatan seperti di atas dimengerti anda

Accertatevi che le suddette norme di sicurezza siano comprese a dovere

上記の注意事項をよくお読みになり、安全を御確認ください

Уверете се дека погоре споменатите мерки на претпазливост се добро разбрани

Asegúrese de que las precauciones de seguridad precedentes sean bien comprendidas

کاری بکنید کہ احتیاطهای بالا حتماً درک بشوند

ต้องแน่ใจว่า ข้อควรระวังเรื่องความปลอดภัยข้างต้น เป็นที่เข้าใจกันดี

Yukarda belirtilen güvenlik önlemlerinin anlaşıldığından emin olunuz

Xin kiểm chắc rằng những biện pháp làm an toàn kể trên được hiểu rõ

Sunbeam's Safety Precautions

SAFETY PRECAUTIONS FOR YOUR SUNBEAM SLOW COOKER.

- Do not operate the slow cooker on an inclined surface.
- Do not move or cover the slow cooker while in operation.
- Do not immerse the base of the slow cooker in water or any other liquid.

Sunbeam is very safety conscious when designing and manufacturing consumer products, but it is essential that the product user also exercise care when using an electrical appliance. Listed below are precautions which are essential for the safe use of an electrical appliance:

- Read carefully and save all the instructions provided with an appliance.
- Always turn the power off at the power outlet before you insert or remove a plug. Remove by grasping the plug - do not pull on the cord.
- Turn the power off and remove the plug when the appliance is not in use and before cleaning.
- Do not use your appliance with an extension cord unless this cord has been checked and tested by a qualified technician or service person.
- Always use your appliance from a power outlet of the voltage (A.C. only) marked on the appliance.
- This appliance is not intended for use by persons (including children) with reduced physical, sensory or mental capabilities, or lack of experience and knowledge, unless they have been given supervision or instruction concerning use of the appliance by a person responsible for their safety.
- Children should be supervised to ensure that they do not play with the appliance.
- The temperature of accessible surfaces may be high when the appliance is operating.

- Use your slow cooker well away from walls and curtains.
- Do not use your slow cooker in confined spaces.
- Do not touch any metal surface of the slow cooker whilst in use as it will be hot.

- Never leave an appliance unattended while in use.
- Do not use an appliance for any purpose other than its intended use.
- Do not place an appliance on or near a hot gas flame, electric element or on a heated oven.
- Do not place on top of any other appliance.
- Do not let the power cord of an appliance hang over the edge of a table or bench top or touch any hot surface.
- Do not operate any electrical appliance with a damaged cord or after the appliance has been damaged in any manner. If damage is suspected, return the appliance to the nearest Sunbeam Appointed Service Centre for examination, repair or adjustment.
- For additional protection, Sunbeam recommend the use of a residual current device (RCD) with a tripping current not exceeding 30mA in the electrical circuit supplying power to your appliances.
- Do not immerse the appliance in water or any other liquid unless recommended.
- Appliances are not intended to be operated by means of an external timer or separate remote control system.
- This appliance is intended to be used in household and similar applications such as: staff kitchen areas in shops, offices and other working environments; farm houses; by clients in hotels, motels and other residential type environments; bed and breakfast type environments.

If you have any concerns regarding the performance and use of your appliance, please visit www.sunbeam.com.au or contact the Sunbeam Consumer Service Line. Ensure the above safety precautions are understood.

Features of your Slow Cooker 5.5L - HP5520

Removable crock insert

The durable ceramic crock insert is removable to allow for convenient serving at the table, storing of leftovers and easy cleaning. The crock insert is also dishwasher safe for added convenience.

Quality glass lid

Fits neatly onto the crock insert to retain heat and moisture for best results. The transparent glass allows you to view the food during cooking without lifting the lid, preventing the heat from escaping.

Temperature control dial

Allows you to select the desired temperature for each recipe. LOW for simmering and slow cooking, HIGH for faster cooking, and KEEP WARM to safely keep your food warm until serving.

Removable cord

For serving at the table and easy storage.

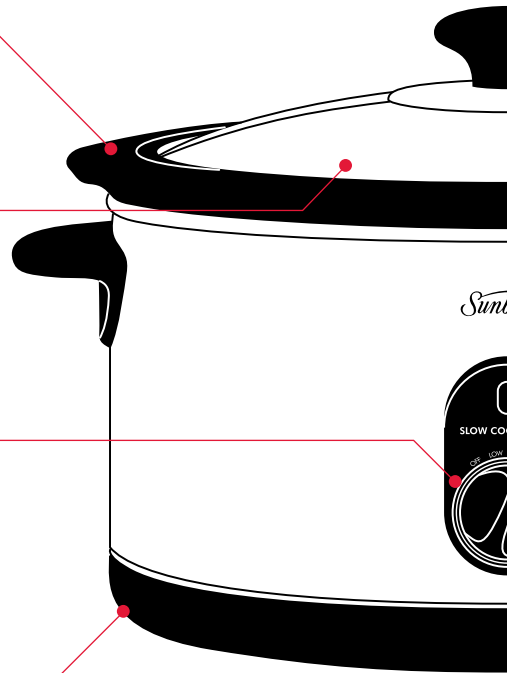

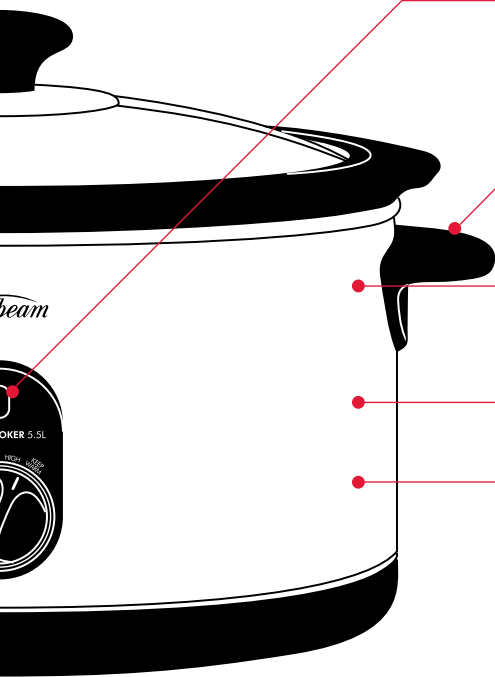

Power ON light

Indicates that the slow cooker is turned on and heating.

Cool touch handles and lid knob

Allows you to lift and carry the slow cooker to the table for serving when hot.

Large 5.5 litre capacity

For cooking large family-sized meals.

Brushed stainless steel housing

Wrap-around element

The element surrounds the crock insert to ensure even cooking. It prevents food from sticking to the bottom of the crock insert and eliminates the need to stir your food.

Features of your Slow Cooker 4.5L - HP4520

Removable crock insert

The durable ceramic crock insert is removable to allow for convenient serving at the table, storing of leftovers and easy cleaning. The crock insert is also dishwasher safe for added convenience.

Quality glass lid

Fits neatly onto the crock insert to retain heat and moisture for best results. The transparent glass allows you to view the food during cooking without lifting the lid, preventing the heat from escaping.

Temperature control dial

Allows you to select the desired temperature for each recipe. LOW for simmering and slow cooking, HIGH for faster cooking, and KEEP WARM to safely keep your food warm until serving.

Removable cord

For serving at the table and easy storage.

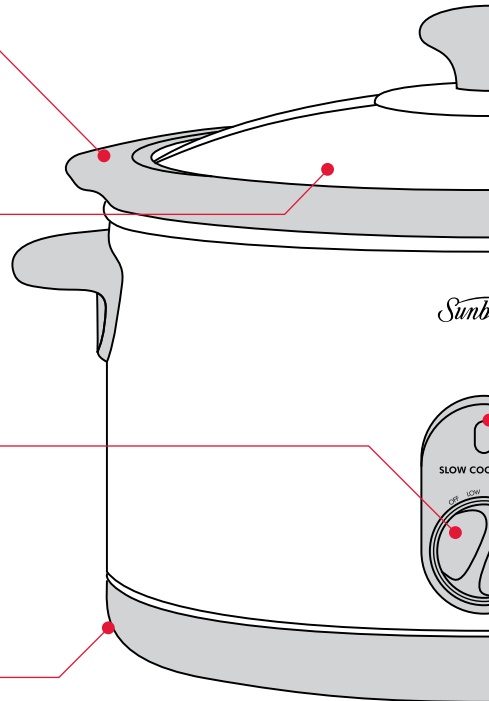

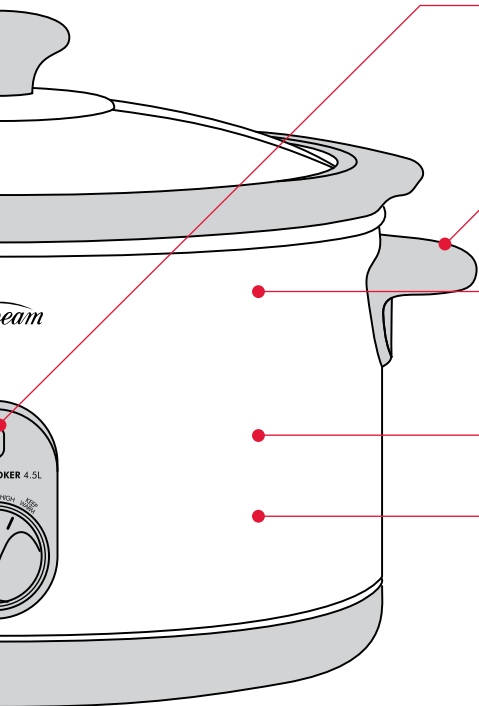

Power ON light

Indicates that the slow cooker is turned on and heating.

Cool touch handles and lid knob

Allows you to lift and carry the slow cooker to the table for serving when hot.

Large 4.5 litre capacity

For cooking medium to large family-sized meals.

Brushed stainless steel housing

Wrap-around element

The element surrounds the crock insert to ensure even cooking. It prevents food from sticking to the bottom of the crock insert and eliminates the need to stir your food.

An Introduction to Slow Cooking

Slow cooking is one of the best ways of preparing foods to ensure that the flavour and tenderness is retained. Your new slow cooker is easy to use and is extremely versatile. You can cook soups, stews, casseroles, roasts, bake desserts and even steam puddings.

Slow cooking is also economical, as your new slow cooker uses very little power.

Once the slow cooker reaches the selected temperature, the food cooks using the heat retained in the crock insert.

Your slow cooker is ideal for cooking tougher cuts of meat as the slow, moist heat tenderises it and enhances the flavours.

Your slow cooker is also very safe for keeping foods heated, as it operates at temperatures high enough to prevent the growth of harmful bacteria.

Using your Slow Cooker

1. Before using your Sunbeam slow cooker for the first time, remove the crock insert and lid and wash them in warm soapy water. Rinse and dry thoroughly and replace.
2. Place the slow cooker on a flat level surface.
3. Prepare the food to be cooked and place inside the slow cooker. Replace the lid.
4. Insert the plug into a 230-240V power outlet and turn the power ON.
5. Select the desired setting on the temperature control dial: LOW, HIGH, or KEEP WARM. The power on light will illuminate to indicate that the appliance is switched on.

Note: Do not place very cold or frozen food in the crock insert if it has been preheated as this may cause the crock insert to crack.

Note: Transfer cooked food from the crock insert into an airtight container before storing in fridge or freezer.

Note: Do not place the crock insert under cold water if it is still hot.

Note: The crock insert is oven safe so you can reheat your precooked dishes in an oven preheated to no more than 160°C.

Important: Food should not be cooked on the KEEP WARM setting as this will not get hot enough to cook. This setting should only be used to keep hot, cooked food warm for serving.

Tips for Slow Cooking

- All of the recipes contained in this book have recommended temperature settings. Most recipes can be cooked on the LOW setting, however when using the HIGH setting cooking times can often be halved.
- Food will be brought to a simmer on all settings. The setting determines the time needed to reach a simmer.
- When cooking with vegetables, place them in the crock insert first, and then place the meat on top.
- Always ensure that food or liquid comes to at least half way up the wall of the crock insert, as the element is located on the sides of the slow cooker.
- When roasting whole pieces of lamb, beef or chicken, it is not necessary to add liquid. Pot roasts and corned meats should be barely covered with liquid.
- Do not use oven bags in your slow cooker.
- When preparing meat for casseroles, lightly coat the pieces in flour and brown before adding to the slow cooker. This helps to seal in the juices and flavours, and keeps the meat tender.
- Frozen casseroles can be placed in the cold slow cooker and heated for 5-8 hours, depending on the quantity. Do not place frozen food into a heated slow cooker.
- If a recipe results in too much liquid, turn the slow cooker to the HIGH setting, remove the lid and cook until sufficient liquid has evaporated.
- To thicken a casserole, set the slow cooker to the HIGH setting and stir through a thickening agent such as cornflour combined with a little water. Allow to simmer until thickened, stirring occasionally.
- Stirring is rarely necessary, as the element wraps around the sides of the slow cooker, preventing the food from sticking to the base.
- Leave the lid on the slow cooker during cooking to maintain heat and moisture.
- Reduce cooking times when the slow cooker is not completely full to achieve a better cooking result as the slow cooker heats up faster when not filled up to the rim.

Care and Cleaning

Wash the crock insert and lid in hot soapy water. To remove food that is cooked onto the bottom, soak the crock insert in warm water before cleaning and scrub lightly with a plastic or nylon brush. Rinse well and dry. The crock insert is also dishwasher safe for added convenience.

Note: Do not place the hot crock insert under cold water.

Wipe the exterior of the slow cooker with a damp cloth and polish dry. **DO NOT** use harsh abrasives, scourers or chemicals to clean any part of your slow cooker as these will damage the surfaces.

CAUTION: Do not immerse the base of the slow cooker in water or any other liquid.

Recipes

Spicy Sweet Potato Soup

Serves 6-8

- 1 tablespoon vegetable oil
- 1 large onion, chopped
- 3 cloves garlic, crushed
- 2-3 tablespoons red curry paste
- 1.5 kg sweet potato (kumara), peeled, diced
- 1 litre chicken stock
- 2 cups water
- ¾ cup light coconut milk
- chopped coriander, to serve

1. Heat oil in a frying pan on a medium-high heat. Cook onion for 2-3 minutes or until softened. Add garlic and red curry paste and cook for 1 minute. Transfer to slow cooker.
2. Add sweet potato, chicken stock and water; stir to combine. Cook on HIGH 3-4 hours or LOW 6-7 hours.
3. Using a stick blender, process soup until smooth. Stir in coconut milk and coriander. Serve.

Chicken, Sweet Corn & Bacon Soup

Serves 6-8

- 5 rashers bacon, rind and fat trimmed, finely chopped
- 1 large brown onion, finely chopped
- 3 cloves garlic, crushed
- 3 trimmed celery sticks, finely chopped
- 3 x 420g can sweet corn kernels, rinsed, drained
- 1.5 litres salt reduced chicken stock
- 2 large (400g) single chicken breast fillets
- 3 green onions, ends trimmed, thinly sliced
- Salt & ground white pepper

1. Heat a non-stick frying pan on a medium-high heat; add bacon and cook for 2 minutes.
2. Stir in onion, garlic and celery. Cook, stirring, for 3-4 minutes then transfer to slow cooker.
3. Add the corn, stock and water and stir to combine. Add chicken. Place lid on and cook on HIGH 2-3 hours.
4. Use tongs to transfer chicken to a bowl. Use a stick blender to blend soup until almost smooth.
5. Shred chicken and add to soup along with the green onions. Taste and season with salt and ground white pepper; replace lid and allow to reheat for 30 minutes on HIGH.

Recipes continued

French Onion Soup

Serves 4-6

- 30g butter
- 1 tablespoon olive oil
- 4 large onions, finely sliced
- 2 cloves garlic, crushed
- 2 tablespoons plain flour
- ¼ cup brandy
- 4 cups beef stock
- 1 Baguette, thickly sliced
- 1 cup of grated Gruyere cheese or ½ cup parmesan

1. Heat oil and butter in a large saucepan over medium heat, until butter is foaming. Add onion and garlic and cook, until onion has softened. Make sure it does not colour.
2. Add flour and coat onion mixture. Gradually add brandy. Cook for 2-3 minutes until alcohol has evaporated. Transfer to slow cooker and add stock.
3. Cover and cook on HIGH 3-4 hours or LOW 6-8 hours.
4. Place bread on a baking tray in one layer, brush or spray with oil. Bake 5-10 minutes or until bread is crisp and lightly coloured. Top bread with cheese and cook a further 5 minutes or until cheese is melting.
5. To serve, place a slice of bread in a soup bowl, ladle in soup and top with extra cheese.

Pea and Ham Soup

Serves 6-8

- 1 tablespoon olive oil
- 2 onions, chopped
- 3 rashers bacon, diced
- 2 cups split peas
- 1- 1.5kg ham bone
- 2 litres water
- 2 large carrots, diced
- 2 sticks celery, sliced
- 2 bay leaves
- 2 tablespoons chopped fresh thyme
- Freshly ground black pepper

1. Heat oil in a large frypan, cook onion and bacon for 2-3 minutes or until onion is soft and bacon is slightly browned. Transfer to slow cooker.
2. Add remaining ingredients, reserving 1 tablespoon of fresh thyme. Cook on HIGH 3-4 hours or LOW 6-8 hours.
3. Remove ham bone from slow cooker. Pull off meat from the bone, removing excess fat and skin. Dice and return to the soup.
4. Stir through remaining thyme and season with freshly ground black pepper.

Recipes continued

Roasting Beef

Heat a small amount of oil on a medium/high heat in a large frying pan; cook beef on all sides until browned. Season with salt and pepper. Place into slow cooker.

Approximate cooking times for well done:

LOW 2-2 ½ hours per 500g

HIGH 1-1 ½ hours per 500g

Roasting Lamb

Trim any excess fat from the lamb. Heat a small amount of oil on a medium/high heat in a large frying pan; cook lamb on all sides until browned. Season with salt and pepper. Place into slow cooker.

Approximate cooking times for well done:

LOW 2-2 ½ hours per 500g

HIGH 1-1 ½ hours per 500g

Roasting Chicken

Wash and pat dry chicken. Place a quartered lemon, 3 cloves garlic and some sprigs of thyme into the cavity of the chicken. Season with salt and pepper and a little paprika.

Approximate cooking times:

LOW 2-2 ½ hours per 500g

HIGH 1-1 ½ hours per 500g

Tip: For a more golden colour chicken simply brown in a frying pan before placing into the slow cooker.

Corned Beef

Serves 6-8

1.5kg corned silverside

1 onion, chopped

10 peppercorns

2 bay leaves

2 tablespoons brown sugar

1. Place silverside into slow cooker; fill with enough water to just cover. Add remaining ingredients.
2. Cover and cook on LOW 8-10 hours or HIGH 4-6 hours.
3. Serve with mashed potatoes and steamed vegetables.

Recipes continued

Spanish Chicken with Capsicums

Serves 4-6

- 2 tablespoons olive oil
- 6 thigh chicken cutlets, fat and skin removed
- 2 red onions, sliced
- 3 cloves garlic, crushed
- 1 ½ teaspoons smoked paprika
- 1 red capsicum, seeds removed, sliced
- 1 yellow capsicum, seeds removed, sliced
- ¼ cup white wine
- ⅓ cup tomato passata
- ⅓ cup pitted kalamata olives, sliced
- 6 artichoke hearts, quartered
- ⅓ cup chopped fresh parsley

1. Heat half the oil in a large non-stick frying pan. Cook chicken in batches until brown. Transfer to slow cooker.
2. Heat remaining oil and cook onions for 2-3 minutes or until softened. Add garlic, paprika and capsicum and cook, stirring for 1 minute. Add to slow cooker with white wine and tomato passata. Cover and cook on HIGH 3-4 hours or LOW 6-7 hours.
3. Stir in olives, artichokes and parsley just before serving.
4. Serve chicken with crusty bread.

Indonesian Chicken Curry

Serves 4-6

- 6 thigh chicken cutlets, fat and skin removed
- ¼ cup flour
- ¼ cup peanut oil
- 1 large onion, sliced
- 3 cloves garlic, crushed
- 3 teaspoons grated fresh ginger
- 1 long red chilli, seeds removed, thinly sliced
- 1 lemongrass, stem finely chopped
- 1 teaspoon ground turmeric
- 2 teaspoons ground cumin
- 2 teaspoons ground coriander
- 1 teaspoon salt
- 600g kumara (sweet potato), peeled, diced
- 1 ⅓ cups coconut milk
- 150g green beans, trimmed, cut into 3cm pieces
- coriander leaves, to serve

1. Dust chicken in flour, shaking off excess flour. Heat half the oil in a large non-stick frying pan. Cook chicken in batches until brown. Transfer to a plate.
2. Heat remaining oil and cook onion for 2-3 minutes or until softened. Add garlic, ginger, chilli, lemongrass, and spices; cook, stirring for 1 minute.
3. Place kumara into the base of slow cooker and top with chicken, onion mixture and coconut milk. Cook on HIGH 3-4 hours or LOW 6-8 hours.
4. Add beans in the last half hour of cooking.
5. Serve chicken with coriander and steamed jasmine rice.

Recipes continued

Chicken, Mustard and Sage Casserole

Serves 6-8

- 8 thigh chicken cutlets, fat and skin removed
- ¼ cup plain flour
- ¼ cup olive oil
- 3 large leeks, washed and sliced thickly
- 2 cloves garlic, crushed
- 1 cup dry white wine
- 1 kg baby new potatoes, halved
- 1 cup chicken stock
- Zest of one lemon
- 2 tablespoons Dijon mustard
- Salt and pepper
- 8 sage leaves, whole
- 1 tablespoon chopped fresh sage

1. Dust chicken in flour, shaking off excess flour. Heat half the oil in a large non-stick frying pan. Cook chicken in batches until brown. Transfer to a plate.
2. Heat remaining oil in frying pan, cook leek and garlic for 3-4 minutes or until leeks have softened. Add wine and cook until reduced by half.
3. Place potatoes into the base of slow cooker and top with chicken and leek mixture. Add remaining ingredients, except chopped sage. Cover and cook on HIGH 3-4 hours or LOW 6-8 hours.
4. Season to taste and sprinkle with sage. Serve with crusty bread.

Hainanese Chicken with Rice

Serves 4-6

- 1.5kg whole chicken, rinsed
- 4 cups water
- 2 green onions, chopped
- 5cm piece ginger, chopped
- 1 teaspoon salt

Topping

- 4 green onions, thinly sliced
- 2 tablespoons finely shredded ginger
- 2 tablespoons peanut oil
- 1 teaspoon sesame oil
- sea salt
- coriander leaves, to serve
- light soy sauce, to serve

1. Place chicken in slow cooker. Add water, green onions, ginger and salt. Cover and cook on HIGH for 2-2 ½ hours.
2. Remove chicken and cut into pieces. Transfer chicken to a serving plate. Top with extra green onions and ginger.
3. Heat peanut oil and sesame oil in a small saucepan until just smoking. Pour hot oil over chicken. Sprinkle with salt and coriander.
4. Serve with soy sauce and steamed rice.

Recipes continued

Lamb Roast with White Beans and Parsley Sauce

Serves 4-6

1.4kg – 1.5kg lamb roast, easy carve
1-2 cloves garlic, cut into slivers
2 sprigs fresh rosemary, cut into pieces
2 tablespoons olive oil
20g butter
1 large onion, sliced
1 x 400g can butter beans, rinsed, drained
¼ cup chopped fresh parsley
½ cup chicken stock
salt and pepper

1. Make small incisions all over lamb with a very sharp knife, then stuff each with a sliver of garlic and a sprig of rosemary.
2. Heat oil in a large frying pan, cook lamb until browned all over. Remove from pan and transfer to slow cooker.
3. In the same pan, add butter and cook onion 1-2 minutes or until softened, place in slow cooker with remaining ingredients. Season with salt and pepper.
4. Cover and cook on HIGH 3-4 hours, or LOW 6-8 hours.
5. Remove meat from slow cooker, and rest for 10 minutes before carving. Serve slices of lamb with beans and parsley sauce.

Lamb Tagine

Serves 6-8

2 tablespoons olive oil
6-8 (depending on size) lamb shanks, fat trimmed
1 large onion, sliced thinly
2 cloves garlic, crushed
1 ½ tablespoons Moroccan dried spice mix
1 tablespoon tomato paste
600g kumara (sweet potato), peeled, diced
1 x 400g tin chopped peeled tomatoes
½ cup chicken stock
1 x 400g can chickpeas, rinsed, drained
1 cinnamon stick
3 cardamom pods, cracked
Salt and pepper to taste
1 cup fresh coriander, roughly chopped
Cous cous, to serve

1. Heat oil in a large frying pan over medium high heat, cook lamb shanks in batches for 3-5 minutes or until evenly brown all over. Transfer to a plate.
2. Reduce heat, and add onion and garlic to frying pan and cook for 2-3 minutes or until onion has softened. Add spice mix and cook until fragrant. Stir through tomato paste.
3. Place kumara into the base of slow cooker and top with lamb and onion mixture and remaining ingredients, except coriander. Cover and cook on HIGH 3-4 hours or LOW 6-8 hours.
4. Season with salt and pepper and stir through chopped coriander, serve with cous cous.

Recipes continued

Rendang Daging – Spicy Coconut Beef Curry

Serves 6-8

- ¼ cup desiccated coconut
- 1 teaspoon ground coriander
- ¼ teaspoon ground turmeric
- 4 kaffir lime leaves, shredded
- 1.5kg chuck steak
- 1 cup coconut milk powder
- 2 tablespoons fish sauce
- Pinch salt

Curry Paste

- 8 dried long red chillies
 - 4 cloves garlic, roughly chopped
 - 8 eschalots, roughly chopped
 - 1 lemon grass stalk, white only, sliced
 - 25g chopped fresh ginger, roughly chopped
 - 25g sliced fresh galangal, roughly chopped
 - pinch salt
1. To make curry paste, soak chillies in hot water until just softened; remove stem and seeds; roughly chop. Place all curry paste ingredients in a food processor and process to a smooth paste; add a little water if necessary.
 2. In a large non-stick frying pan over a low heat, lightly toast coconut until lightly golden; remove from heat and allow to cool. Once cool, process in a food processor to a fine powder.
 3. Heat a large non-stick frying pan; add curry paste, coriander, turmeric and lime leaves and cook, stirring, for about 5 minutes or until fragrant.
 4. Add beef and stir until browned. Place beef, desiccated coconut, coconut milk powder and fish sauce into the slow cooker and stir to combine.
 5. Cover and cook on HIGH 4-5 hours or LOW 6-8 hours. Stir once during cooking.

Veal Goulash

Serves 6

- 1.5kg veal, cut into 2cm pieces
 - ¼ cup flour
 - ⅓ cup olive oil
 - 2 onions, chopped
 - 3 cloves garlic, crushed
 - 2 tablespoons Hungarian sweet paprika
 - ½ teaspoon cayenne pepper
 - 2 large potatoes, peeled, diced
 - 1 cup beef stock
 - 2 tablespoons tomato paste
 - 2 bay leaves
 - salt and freshly ground black pepper
1. Dust veal in flour, shaking off excess flour.
 2. Heat half the oil in large non-stick frying pan. Cook veal in batches until brown. Transfer to a plate.
 3. Heat remaining oil and cook onion for 2-3 minutes or until softened. Add garlic, paprika and cayenne pepper and cook, stirring for 30 seconds.
 4. Place potatoes in base of slow cooker. Add veal and remaining ingredients to slow cooker. Cover and cook on HIGH 3-4 hours or LOW 6-8 hours.
 5. Serve with hot pasta.

Recipes continued

Family Beef Casserole with Semi Dried Tomatoes

Serves 6-8

- 2 kg chuck or round steak, diced
 - ½ cup flour
 - 3 tablespoons olive oil
 - 2 bunches of spring onion, stalk trimmed, peeled and left whole
 - 3 cloves garlic, crushed
 - 3 carrots, diced
 - 4 celery stalks, sliced
 - ⅓ cup tomato paste
 - ½ cup red wine
 - 1 cup semi dried tomatoes
 - 2 tablespoons chopped fresh thyme
 - 2 bay leaves
 - Salt and freshly ground black pepper
1. Dust beef in flour, shaking off excess flour. Heat half the oil in a large frying pan and cook beef in batches until brown. Transfer to slow cooker.
 2. Heat remaining oil and cook onion and garlic for 1-2 minutes or until onion is softened. Add carrots, celery and tomato paste and cook for a further 3 minutes.
 3. Add wine and allow alcohol to evaporate and liquid to reduce slightly.
 4. Place vegetables and remaining ingredients in slow cooker. Stir through. Cover and cook on HIGH 3-4 hours or LOW 5-6 hours.
 5. Season to taste and serve hot with mashed potatoes or thick sliced Italian bread.

Beef Brisket with Vegetables

Serves 6-8

- 1 large carrot, cut into matchsticks
 - 2 large potatoes, diced
 - 1.5kg rolled beef brisket
 - ¼ cup seasoned flour
 - 2 tablespoons olive oil
 - 2 onions, cut into wedges
 - 3 cloves garlic, crushed
 - 1 cup tomato passata
 - 1 cup beef stock
 - 2 bay leaves
 - 10 thyme sprigs
 - salt and freshly ground black pepper
1. Place carrot and potatoes in base of slow cooker.
 1. Dust beef in flour, shaking off excess flour.
 2. Heat half the oil in a large non-stick frying pan. Cook beef until brown. Transfer to slow cooker.
 3. Heat remaining oil and cook onion for 2-3 minutes or until softened. Add garlic and cook, stirring for 30 seconds. Add to slow cooker with remaining ingredients.
 4. Cover and cook on HIGH 4-5 hours or LOW 6-8 hours.
 5. Transfer meat to a plate, cover with foil and stand for 10 minutes before slicing.
 6. Using a large spoon, skim any fat from the top.
 7. Serve beef with vegetables and sauce.

Recipes continued

Pork with Prunes and Apricots

Serves 6

- 1.2kg roast leg pork
- 1 tablespoon olive oil
- 2 onions, cut into wedges
- 3 cloves garlic, crushed
- 2 teaspoons ground cumin
- 2 teaspoons ground coriander
- 1/3 cup orange juice
- 1/3 cup tomato passata
- 1/2 cup chicken stock
- 1 tablespoon tomato paste
- 150g pitted prunes
- 100g dried apricots

1. Place pork into slow cooker. Heat oil in a large non-stick frying pan. Cook onions for 2-3 minutes or until softened. Add garlic, cumin and coriander and cook, stirring for 30 seconds.
2. Add to slow cooker with remaining ingredients. Cover and cook on HIGH 4 hours or LOW 6-8 hours.
3. Transfer pork to a plate, cover with foil and stand for 10 minutes before slicing.
4. Serve pork with sauce and steamed cous cous.

Dhal

Serves 6-8

- 2 tablespoons vegetable oil
- 2 medium onions, finely chopped
- 2 cloves garlic, crushed
- 1 tablespoon ground cumin
- 1 teaspoon cumin seeds
- 2 teaspoons black mustard seeds
- 1/4 cup tomato paste
- 4 cups red lentils
- 2 cups vegetable stock
- 4 1/2 cups water
- 2 x 400g can chopped tomatoes
- 3 baby eggplants, roughly chopped
- salt to taste

1. In a large frying pan, heat oil over medium heat. Add onion and garlic and cook, for 2-3 minutes or until onion is softened.
2. Add dried spices and cook a further 1 minute, or until spices are fragrant. Stir through tomato paste and cook for 2 minutes. Place in slow cooker.
3. Rinse lentils in water, until water runs clear. Put in slow cooker with remaining ingredients, except salt and stir well to combine all ingredients.
4. Cook on HIGH 1-2 hours or LOW 4-5 hours.
5. Season to taste, serve hot.

Recipes continued

Ratatouille

Serves 4

- 1 large onion, chopped
- 2 cloves garlic, crushed
- 2 tablespoons tomato paste
- 1 large eggplant, cut into 3 cm dice
- 2 zucchinis, sliced into 1 cm rings
- 1 medium red capsicum, deseeded and chopped into 3 cm pieces
- 1 medium green capsicum, deseeded and chopped into 3 cm pieces
- 2 x 400g can chopped tomatoes
- 2 tablespoons chopped fresh thyme
- Salt and freshly ground black pepper
- 1. Place all ingredients except salt and pepper in slow cooker. Cover and cook on HIGH 2-3 hours or LOW 5-6 hours.
- 2. When ready to serve, season to taste.

Potato Bake with Creamy Bacon Sauce

Serves 6-8

- 1 tablespoon olive oil
- 2 leeks, trimmed, washed, thinly sliced
- 175g bacon, diced
- 1.5kg potatoes (Sebago), peeled, thinly sliced
- 2 cups pouring cream
- 1 tablespoon dijon mustard
- ¼ cup milk
- Salt and freshly ground black pepper
- ¾ cup grated parmesan cheese
- 1. Heat oil in a large non-stick frying pan. Cook leek and bacon for 2-3 minutes or until leek is soft and bacon is slightly browned.
- 2. Place a third of potatoes in slow cooker. Layer with half the leek and bacon mixture. Repeat, finishing with potatoes.
- 3. Combine cream, mustard, milk, salt and pepper in a jug. Pour over potatoes. Sprinkle with cheese. Cover and cook on HIGH for 3 hours. Stand for 30 minutes before serving.

Recipes continued

Balsamic Glazed Beetroots

Serves 6

4 bunches small beetroots, (about 16)
2 tablespoons water
2 tablespoons balsamic vinegar
1 teaspoon dried mixed herbs
2 cloves garlic, crushed
1 tablespoon finely chopped dill
sour cream, to serve

1. Wash beetroots, peel and cut in halves or quarters.
2. Place beetroot, water, balsamic vinegar, herbs and garlic in slow cooker.
3. Cover and cook on HIGH for 3 hours.
4. Serve beetroot with juice, chopped dill and sour cream.

Hearty Homemade Beans

Serves 6

1 ½ cups dried cannellini beans, soaked overnight
1 tablespoon olive oil
1 small onion, finely chopped
175g shortcut bacon, finely chopped
3 cloves garlic, crushed
1 small carrot, finely chopped
1 small celery stick, finely chopped
2 tablespoons tomato paste
2 x 400g can diced tomatoes
¼ cup chicken stock
¼ cup chopped fresh flat-leaf parsley
salt and freshly ground black pepper

1. Place beans in a large bowl and cover with water. Soak beans overnight in the fridge.
2. Heat oil in a large non-stick frying pan. Cook onion and bacon for 2-3 minutes or until soft. Add carrot and celery and cook for a further 2 minutes.
3. Transfer to slow cooker with tomatoes and stock. Cover and cook on HIGH 4-5 hours or LOW 6-8 hours.
4. Stir through parsley and season with salt and pepper.

Recipes continued

Crème Caramel

Serves 4

- ½ cup caster sugar
- 2 tablespoons water
- 3 eggs
- 2 egg yolks
- ⅓ cup caster sugar, extra
- 250ml milk
- 200ml pouring cream
- 1 vanilla bean, seeds scraped

1. Turn slow cooker to HIGH and add 2 cups hot water.
2. Lightly spray 4 x 1 cup metal moulds with cooking spray.
3. Combine sugar and water in a small saucepan. Stir over low heat until the sugar has dissolved. Increase heat; boil without stirring, until the toffee turns a golden colour. Remove from heat, once the bubbles have subsided, pour into moulds. Allow to cool.
4. Beat eggs and sugar until light and creamy.
5. Heat milk, cream, vanilla bean and seeds until almost boiling. Whisk hot milk into egg mixture. Pour mixture through a strainer.
6. Pour mixture into moulds. Place in slow cooker. Turn slow cooker to LOW and cook for 1 hour or until just set. Remove from slow cooker and refrigerate for several hours.
7. To remove, carefully run a thin knife or spatula around edge of custard. Invert onto a serving plate.

Creamy Coconut Vanilla Rice

Serves 6

- 1 cup medium grain rice (such as calrose)
 - ¾ cup brown sugar
 - 2 vanilla beans, split
 - 4 cups milk
 - 270ml can coconut cream
1. Place rice, sugar, vanilla and milk in slow cooker. Cover and cook on HIGH for 3 ½ hours, stirring 2-3 times.
 2. Stir in coconut cream. Cover and cook on LOW for a further 30 minutes.
 3. Serve with fresh berries, if desired.

Recipes continued

Poached Pears in Red Wine and Star Anise

Serves 4-6

1 ½ cups dry red wine

¾ cup sugar

3 star anise

6 medium pears, peeled

3 thick strips lemon rind

1. Preheat slow cooker for 10 minutes on HIGH.
2. Place wine, sugar and star anise into the slow cooker. Cover and cook on HIGH until sugar is dissolved.
3. Place pears into the slow cooker, turning to coat well with sugar syrup. Add lemon peel, cover and cook on HIGH 1-1 ½ hours or LOW 3-4 hours, turning occasionally to coat.
4. To serve, remove pears from the slow cooker and place onto a serving plate. Pour syrup over pears. Serve with ice cream if desired.

Spiced Rhubarb and Berry Compote

Serves 4-6

2 bunches of rhubarb

500g frozen mixed berries

¾ cup sugar

1 cinnamon quill

3 whole cloves

1 teaspoon grated orange rind

1. Discard leaves from rhubarb. Wash stalks thoroughly and cut into 2cm pieces.
2. Combine all ingredients in the slow cooker.
3. Cover and cook on LOW 3-4 hours.
4. Serve hot with ice cream or with your favourite pudding.

Recipes continued

Steamed Christmas Pudding

Serves 8

- 500g mixed dried fruit
- ½ cup brown sugar, firmly packed
- 90g butter or margarine
- ⅓ cup sherry or brandy
- ½ teaspoon bi-carbonate of soda
- 2 eggs, lightly beaten
- 1 cup self raising flour
- ½ teaspoon mixed spice

1. In a saucepan, combine mixed fruit, brown sugar, butter and sherry. Heat until butter is melted and mixture begins to boil.
2. Remove from heat, add bi-carbonate of soda and allow to cool completely.
3. Grease a 6 cup capacity pudding bowl.
4. Add eggs to the cooled mixture and mix until well combined. Fold through flour and spices.
5. Pour mixture into the prepared bowl, cover with a double layer of foil and tie firmly with string to form a good seal.
6. Place into the slow cooker. Pour in sufficient water to come two thirds of the way up the sides of the pudding bowl. Cover and cook on HIGH for 5-7 hours.
7. Re-heat pudding by cooking pudding in water on HIGH for 2-3 hours prior to serving. Serve with brandy custard.

Chocolate Self-Saucing Pudding

Serves 4

- 100g unsalted butter, melted
- ½ cup milk
- 1 egg
- 1 cup self-raising flour
- 2 tablespoons cocoa
- ½ cup caster sugar

Topping:

- 2 tablespoons cocoa
 - 1 cup firmly packed brown sugar
 - 2 cups boiling water
1. In a mixing bowl, combine butter, milk and egg.
 2. In a separate large bowl, sift flour and cocoa together and mix in the sugar.
 3. Gradually add the wet ingredients into the flour mixture and mix well. Spoon into a 6 cup capacity pudding bowl, and place in the slow cooker. No water is needed around bowl.
 4. Combine the cocoa and brown sugar together, sprinkle over the top of pudding. Carefully pour boiling water over the mixture.
 5. Cover and cook on HIGH 3 ½ hours or on LOW 5-6 hours.
 6. Serve hot with ice cream or custard.

Notes

Notes

12 Month Replacement Guarantee

In the unlikely event that this appliance develops any malfunction within 12 months of purchase (3 months commercial use) due to faulty materials or manufacture, we will replace it for you free of charge.

Should you experience any difficulties with your appliance, please phone our customer service line for advice on 1300 881 861 in Australia, or 0800 786 232 in New Zealand. Alternatively, you can send a written claim to Sunbeam at the address listed below. On receipt of your claim, Sunbeam will seek to resolve your difficulties or, if the appliance is defective, advise you on how to obtain a replacement or refund.

Your Sunbeam 12 Month Replacement Guarantee naturally does not cover misuse or negligent handling and normal wear and tear.

Similarly your 12 Month Replacement Guarantee does not cover freight or any other costs incurred in making a claim. Please retain your receipt as proof of purchase.

The benefits given to you by this guarantee are in addition to your other rights and remedies under any laws which relate to the appliance.

Our goods come with guarantees that cannot be excluded under the Australian Consumer Law and under the New Zealand Consumer Guarantees Act.

In Australia you are entitled to a replacement or refund for a major failure and for compensation for any other reasonably foreseeable loss or damage. You are also entitled to have the goods repaired or replaced if the goods fail to be of acceptable quality and the failure does not amount to a major failure.

Should your appliance require repair or service after the guarantee period, contact your nearest Sunbeam service centre.

For a complete list of Sunbeam's authorised service centres visit our website or call:

Australia

www.sunbeam.com.au

1300 881 861

Units 5 & 6, 13 Lord Street
Botany NSW 2019 Australia

New Zealand

www.sunbeam.co.nz

0800 786 232

26 Vestey Drive, Mt Wellington
Auckland, New Zealand

Need help with your appliance?

Contact our customer service team or visit our website for information and tips on getting the most from your appliance.

In Australia

Visit www.sunbeam.com.au

Or call 1300 881 861

In New Zealand

Visit www.sunbeam.co.nz

Or call 0800 786 232

 is a registered trademark.

Made in China.

Due to minor changes in design or otherwise, the product may differ from the one shown in this leaflet.

© Copyright. Sunbeam Corporation Limited 2011.

ABN 45 000 006 771

Units 5 & 6, 13 Lord Street
Botany NSW 2019 Australia

Unit 3, Building D
26 Vestey Drive
Mt Wellington Auckland
New Zealand

Sunbeam Corporation is a division of GUD Holdings Ltd.